

# RESTRAINT COUPLING



## Briefs

- Connection for HDPE pipe;
- Working pressure PN10/16;
- Maximum temperature -10 °C to +70 °C;
- Suitable for portable water, neutral liquids and sewage;
- WRAS approved.

## Standards

- Coating: EN30677;
- Test: EN 12266-1.

## Features

- Corrosion resistant construction;
- Angular deflection  $\pm 3^\circ$ .

## Options

- A2-70, A4-80 etc;
- Various coating;
- Seal: NBR etc.

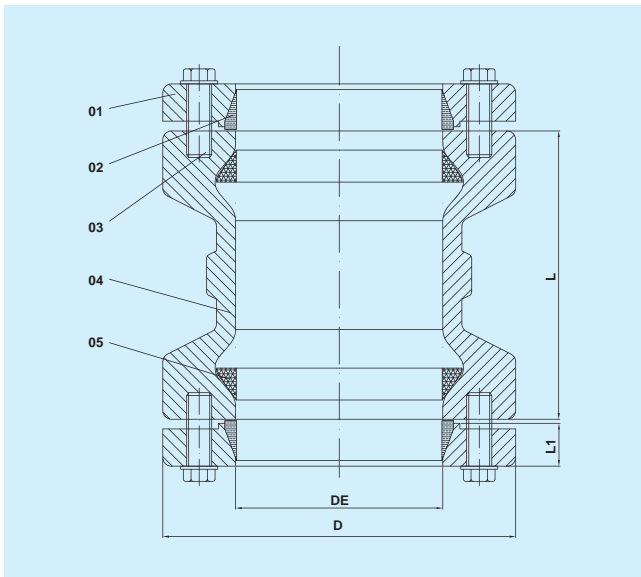

## Assembly Chart

ITEM	DESCRIPTION	MATERIAL	STANDARD
1	END RING	EN GJS400-15	EN 1563
2	GRIP	BRASS	EN1982
3	FASTENER	STAINLESS STEEL	ASTM A276
4	SLEEVE	EN GJS400-15	EN 1563
5	GASKET	EPDM	EN 681-1

## Specifications & Parameters Chart

DE	L1 mm	L mm	D mm	BOLT M×No.
63	20	125	130	M10×2
75	21	126	142	M10×4
90	21	128	160	M10×4
110	22	130	180	M10×4
125	22.5	134	195	M10×4
140	22.5	145	221	M10×4
160	23.5	170	235	M10×4
180	23.5	185	255	M10×4
200	25	210	274	M10×4
225	25	215	302	M10×4
250	25	240	328	M10×6
280	25	250	358	M10×6
315	25	300	392	M10×6