

# TAPPER SADDLE



## Briefs

- Connection for pipes in material PE, PVC etc;
- Working pressure PN10/16;
- Maximum temperature -10 °C to +70 °C ;
- Suitable for portable water, neutral liquids and sewage.

## Standards

- Coating: EN30677;
- Test: EN 12266-1.

## Features

- Corrosion resistant construction.

## Options

- GD8.8, A2-70, A4-80, Dacromet bolt;
- Various coating;
- Seal: NBR etc;
- M thread type: G3/4", G1", G1"1/4, G1"1/2, G2".

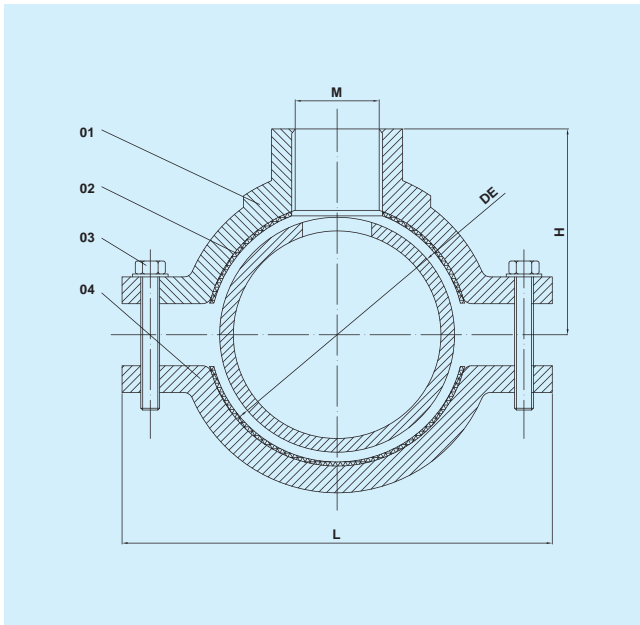

## Assembly Chart

ITEM	DESCRIPTION	MATERIAL	STANDARD
1	UPPER BODY	EN GJS400-15	EN 1563
2	GASKET	EPDM	EN 681-1
3	FASTENER	STAINLESS STEEL	ASTM A276
4	LOWER BODY	EN GJS400-15	EN 1563

## Specifications & Parameters Chart

DE	H mm	L mm	BOLT	
			SIZE	QTY
50	63	125	M10X30	4
63	66	125	M10X35	4
75	71	136	M10X40	4
90	78	152	M10X40	4
110	87	174	M10X45	4
125	100	193	M12X50	4
140	100	215	M12X50	4

DE	H mm	L mm	BOLT	
			SIZE	QTY
160	118	234	M12X55	4
180	135	266	M12X60	6
200	135	285	M12X60	6
225	142	305	M12X70	6
250	164	330	M12X70	6
280	172	361	M12X70	6
315	195	393	M12X80	6