

RESILIENT SEATED GATE VALVE WITH ISO TOP FLANGE

BS5163 DN700-DN1200

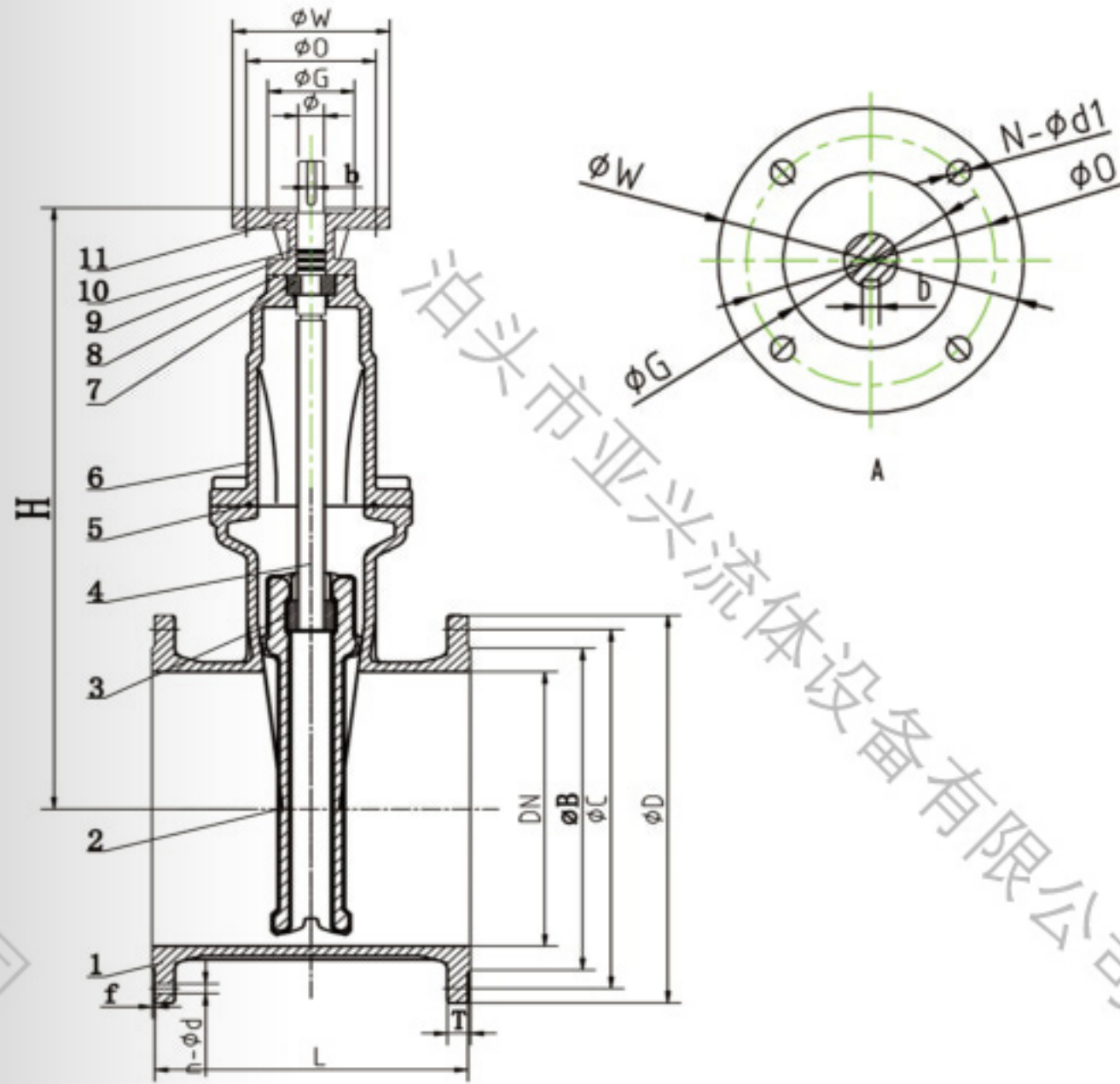

Part & Materials		
NO	Part	Material
1	Body	Ductile Iron GGG50
2	Wedge	Ductile Iron GGG50 +EPDM
3	Stem Nut	Brass
4	Stem	SS420
5	Gasket	EPDM
6	Bonnet	Ductile Iron GGG50
7	Locating Ring	Brass
8	O Ring	EPDM
9	Bolts	CS Gr 12.9
10	O Ring	EPDM
11	Flange	Ductile Iron GGG50

Technical Data		
NO	Description	Specification
1	Nominal Dia	DN700-DN1200
2	Nominal Pressure	PN10&PN16
3	Valve Design Standard	BS5163
4	Face to Face Standard	EN558&ISO5752 Series-3
5	Flange Standard Conformity	EN1092-2
6	Testing Standard	EN12266-1
7	Expoxy Coating	Epoxy powder coating with minimum thickness of 250 microns inside and outside.
8	Testing Pressure	
	Shell Test	PN*1.5Times
	Sealing Test	PN*1.1Times
9	Working Temperature(Max)	120°C

DIMENSIONS (MM) * THE MENTIONED TORQUE DO NOT INCLUDE ANY SAFETY FACTOR.

PN10																
DN	L	D	C	B	n-Ød	T	f	N-d1	W	O	G	Φ	b	Torque (N.m)	Turns	H
DN700	610	895	840	794	24-31	32.5	5	4-22	210	165	130	40	12	400	35	1380
DN750	610	960	900	857	24-31	32.5	5	4-22	210	165	130	40	12	400	35	1380
DN800	660	1015	950	901	24-34	35	5	4-22	210	165	130	40	12	420	40	1555
DN900	711	1115	1050	1001	28-34	37.5	5	8-18	300	254	200	50	14	480	45	1735
DN1000	813	1230	1160	1112	28-37	40	5	8-18	300	254	200	50	14	550	50	1910
DN1100	813	1340	1270	1221	32-37	42	5	8-18	300	254	200	50	14	600	55	2080
DN1200	1015	1455	1380	1328	32-40	45	5	8-18	300	254	200	50	14	600	60	2220

PN16																
DN	L	D	C	B	n-Ød	T	f	N-d1	W	O	G	Φ	b	Torque (N.m)	Turns	H
DN700	610	910	840	794	24-37	39.5	5	4-22	210	165	130	40	12	400	35	1380
DN750	610	970	900	857	24-37	41	5	4-22	210	165	130	40	12	400	35	1380
DN800	660	1025	950	901	24-40	43	5	4-22	210	165	130	40	12	420	40	1555
DN900	711	1125	1050	1001	28-40	46	5	8-18	300	254	200	50	14	480	45	1735
DN1000	813	1255	1170	1112	28-43	50	5	8-18	300	254	200	50	14	550	50	1910
DN1100	813	1355	1270	1218	32-43	53.5	5	8-18	300	254	200	50	14	600	55	2080
DN1200	1015	1485	1390	1328	32-49	57	5	8-18	300	254	200	50	14	600	60	2220

Yaxing product specifications in this catalog are for reference only. Yaxing reserves the rights to change without prior notice.