

# GATE VALVE

## SOCKET END RESILIENT SEATED GATE VALVE DN50-DN300

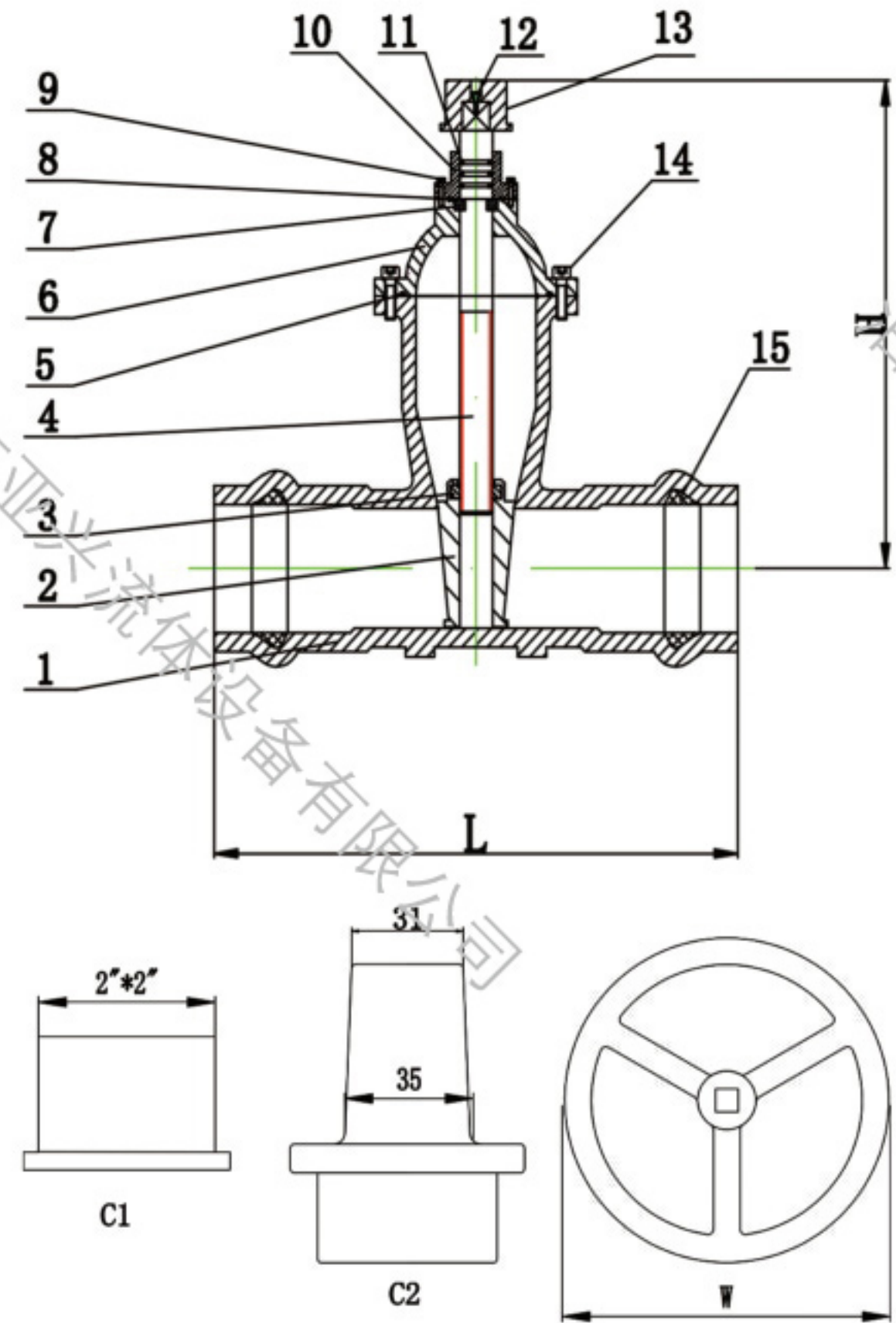

Part & Materials		
NO	Part	Material
1	Body	Ductile Iron GGG50
2	Wedge	Ductile Iron GGG50+EPDM
3	Stem Nut	Brass/DI
4	Stem	SS420
5	Gasket	EPDM
6	Bonnet	Ductile Iron GGG50
7	Locating Ring	Brass/DI
8	O Ring	NBR
9	Bolts	CS Gr 8.8
10	Gland	Ductile Iron GGG50
11	O Ring	EPDM
12	Bolts	CS Gr 8.8
13	Handwheel/Cap	Ductile Iron GGG50
14	Bolts	CS Gr 8.8
15	Sealing Ring	NBR

Technical Data		
NO	Description	SSpecification
1	Nominal Dia	DN50-DN300
2	Nominal Pressure	PN10&PN16
3	Valve Design Standard	DIN3352 F5
4	Face to Face Standard	EN558&ISO5752 Series-15
5	Socket Standard Conformity	EN12842
6	Testing Standard	EN12266-1
7	Expoxy Coating	Epoxy powder coating with minimum thickness of 250 microns inside and outside.
8	Testing Pressure	
	Shell Test	PN*1.5Times
	Sealing Test	PN*1.1Times
9	Working Temperature(Max)	120°C

### DIMENSIONS (MM)

	DN50	DN65	DN80	DN100	DN150	DN200	DN250	DN300
PVC TUDE	63MM	75MM	90MM	110MM	160MM	200MM	250MM	315MM
L	250	270	280	300	350	400	450	500
C1	2"×2"	2"×2"	2"×2"	2"×2"	2"×2"	2"×2"	2"×2"	2"×2"
C2	31×35	31×35	31×35	31×35	31×35	31×35	31×35	31×35
W	160	160	180	200	250	300	330	380
H	200	210	250	280	385	460	580	640

Yaxing product specifications in this catalog are for reference only. Yaxing reserves the rights to change without prior notice.