

PRESSURE RELIEF VALVE DN50-DN800

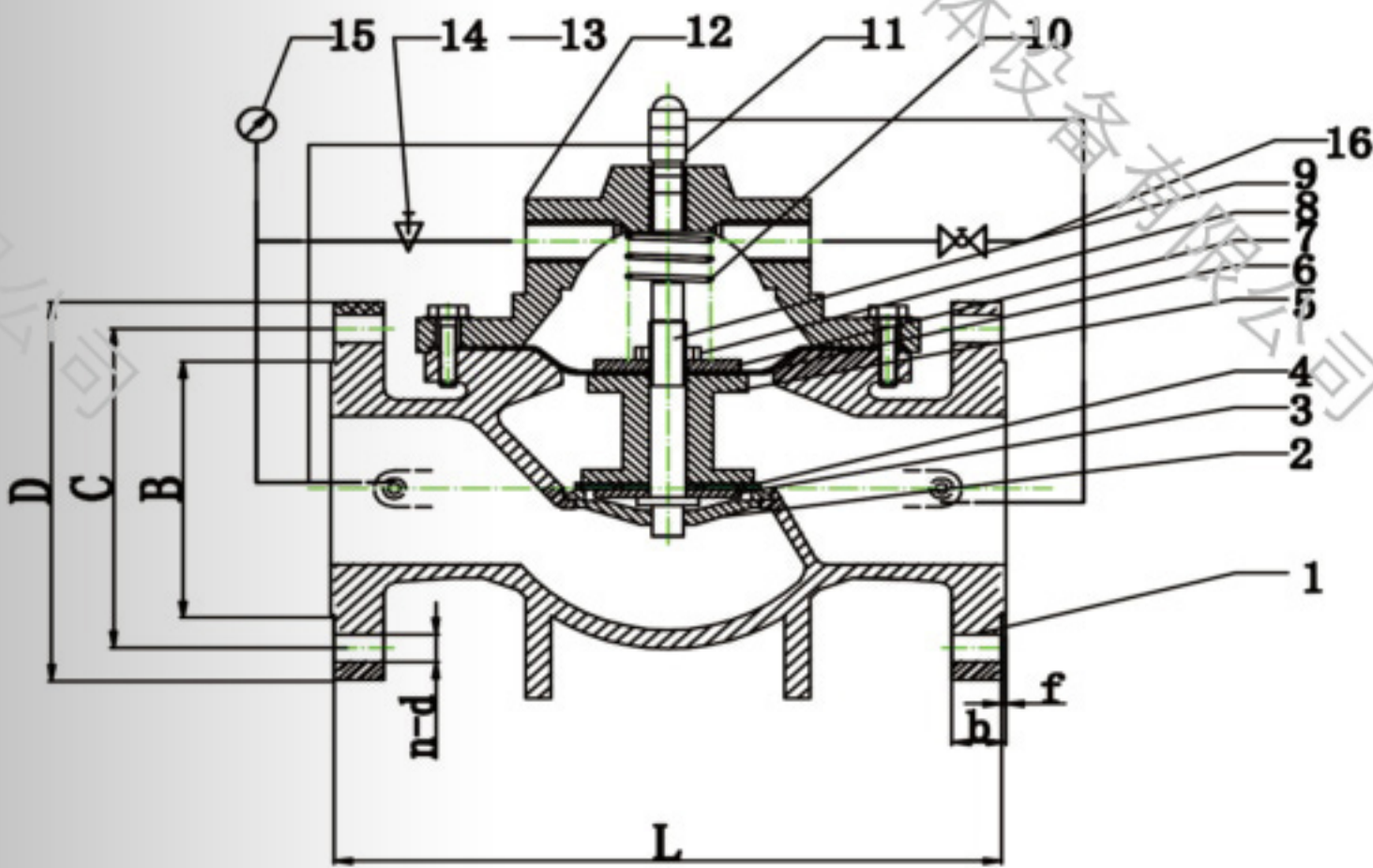

Part & Materials		
NO	Part	Material
1	Body	Ductile Iron GGG50
2	Seat	Brass
3	Platen	CS
4	Sealing	EPDM
5	Disc	Ductile Iron GGG50
6	Dlamphragm	EPDM
7	Platen	CS
8	Nut	Stainless Steel
9	Stem	SS410
10	Spring	Stainless Steel
11	Pressure Relief Pilot Valve	SS304
12	Bonnet	Ductile Iron GGG50
13	Bolts	A2-70
14	Needle Valve	SS304
15	Pressure Gauge	-
16	Globe Valve	SS304

Technical Data		
NO	Description	Specification
1	Nominal Dia	DN50-DN800
2	Nominal Pressure	PN10&PN16
3	Flange Standard Conformity	EN1092-2
4	Epoxy Coating	Epoxy powder coating with minimum thickness of 250 microns inside and outside.
5	Working Temperature(Max)	80°C

DIMENSIONS (MM)

DN	L	D		C		B		n-d		b		f
		PN10	PN16	PN10	PN16	PN10	PN16	PN10	PN16	PN10	PN16	
DN50	240	160		125		99		4-19		19		3
DN65	240	180		145		119		4-19		19		3
DN80	292	195		160		133		8-19		19		3
DN100	325	215		180		154		8-19		19		3
DN125	340	245		210		184		8-19		19		3
DN150	400	280		240		210		8-23		19		3
DN200	435	335		295		265		8-23	12-23	20		3
DN250	510	405		350	355	319		12-23	12-28	22		3
DN300	600	460		400	410	370		12-23	12-28	24.5		4
DN350	675	520		460	470	429		16-23	16-28	26.5		4
DN400	730	575		515	525	480		16-28	16-31	28		4
DN450	720	635		565	585	530		20-28	20-31	30		4
DN500	790	710		620	650	582	609	20-28	20-34	31.5		4
DN600	970	840		725	770	682	720	20-31	20-37	36		5
DN700	1120	910		840		794		24-31	24-37	39.5		5
DN800	1200	1025		950		901		24-34	24-40	35	43	5

Yaxing product specifications in this catalog are for reference only. Yaxing reserves the rights to change without prior notice.